

BARIL

1-800-463-3871

GUIDE D'INSTALLATION / INSTALLATION GUIDE

Robinet de lavabo mural deux manettes

Two handles wall-mounted lavatory faucet

TXX-8041-00S_PLAN

V0

GUIDE D'INSTALLATION / INSTALLATION GUIDE

- Lire attentivement le présent guide avant l'installation.
- Baril se réserve le droit d'apporter toute modification au design du produit et ceci sans préavis.
- *Read this guide before proceeding with the installation.*
- *Baril reserves the right to make any changes to the design of the product, without notice.*

***CE PLAN D'INSTALLATION PEUT SERVIR POUR PLUSIEURS MODÈLES.**

***THIS INSTALLATION PLAN MAY APPLY TO SEVERAL MODELS.**

LES OUTILS DONT VOUS AUREZ BESOIN TOOLS YOU WILL NEED

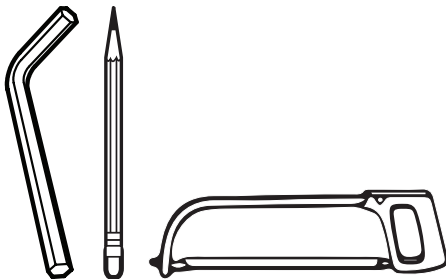

TEMPS DE MONTAGE ESTIMÉ
ESTIMATED ASSEMBLY TIME



+/- 45 min.

LÉGENDE REFERENCE



Options
Options



Eau froide
Cold water



Attention
Warning



Eau chaude
Hot water

Conseils, astuces et précautions avant de commencer

- Veuillez vous informer des différentes règles et exigences du code de plomberie en vigueur dans votre région avant l'installation.
- Il est recommandé de faire appel à un plombier professionnel pour tous les travaux d'installation et de réparation.
- Toujours enlever la cartouche lors de l'installation. Remettre la cartouche après que la purge de la tuyauterie a été effectuée.
- Le Code national de la plomberie du Canada exige l'installation d'anti-bélier, afin d'amortir les coups de bélier dans la tuyauterie.
- Ne jamais essayer d'arrêter l'égouttement en utilisant une force excessive pour fermer la valve.
- Il est recommandé de laver les produits à l'aide d'un savon doux liquide non-abrasif, de l'eau tiède et d'un chiffon doux. Ne jamais utiliser de produits abrasifs, chimiques, corrosifs, en poudre ou très forts incluant dentifrices, détergents, récurants, nettoyeurs pour vitre et désinfectants.

Tips, tricks and warnings before you begin

- Take note of the different standards and rules your local and municipal plumbing codes have in effect before installing.
- We recommend the use of services offered by a professional plumber for any installation or repair work.
- Always remove the cartridge during installation. Once the purge of the pipes is completed, place back the cartridge.
- The National Plumbing Code of Canada requires the installation of air chambers or surge arresting devices to eliminate water hammers.
- At no time attempt to stop dripping by applying extreme force when closing the valve.
- We recommend that products be cleaned with a mild, non-abrasive liquid soap, warm water and soft cloth. Never use abrasive products, chemicals, corrosives that are very strong or in powder form, including toothpaste, detergents, scouring products, window cleaners and disinfectants.



Dessin technique.
Technical drawing.

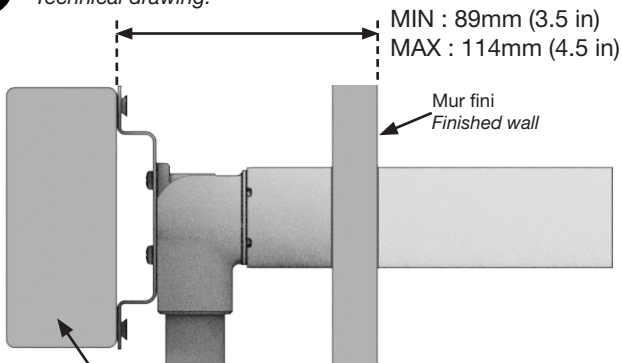

Support de bois 2"x 4" (min) entre les montants.
2"x 4" (min) reinforcement support between the studs.



Attention de bien fixer le brut à niveau horizontalement sur la largeur et la profondeur

Be careful to level rough-in both widthwise and depthwise



Gabarit de perçage
Hole template

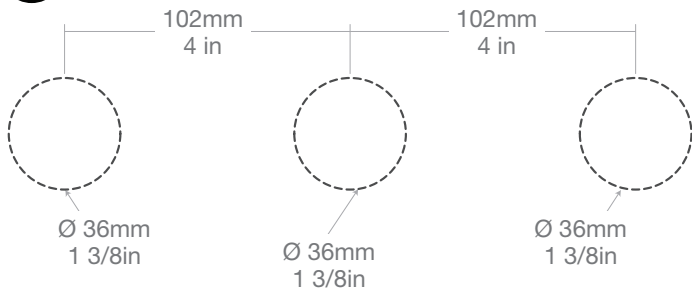

1

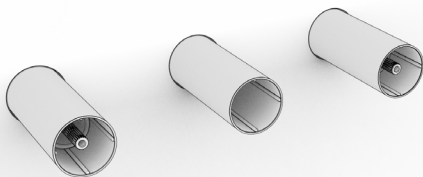

Fermer l'alimentation d'eau principale avant de procéder à l'installation de la finition du robinet.

Turn off the water main before starting to install the finished faucet.

2

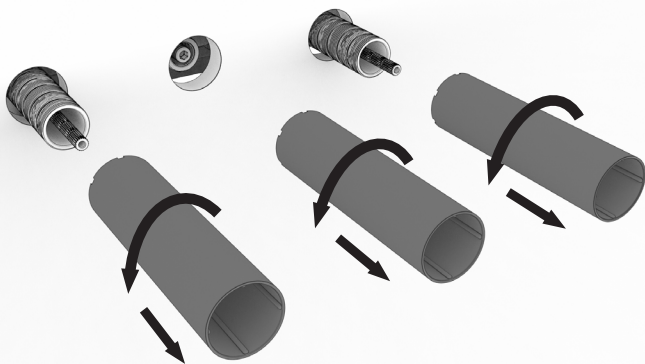

3

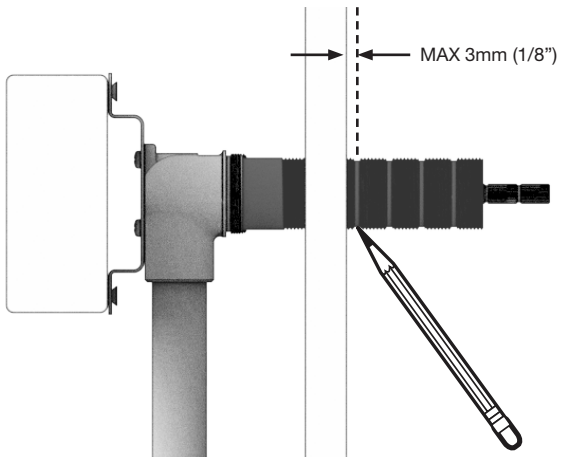

4

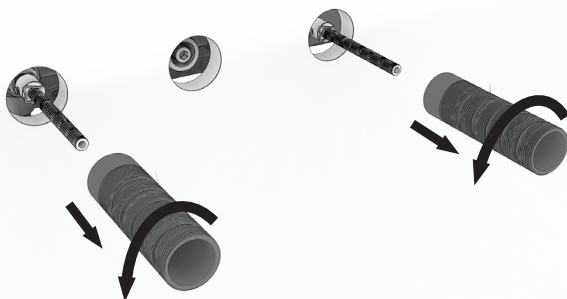

5

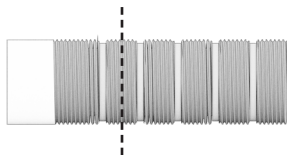

À l'aide d'une scie, couper dans l'espace sans filets le plus court, près de la ligne tracée à l'étape 3.

With the help of a saw, cut in the closest groove on the short side from the marked line from step 3.

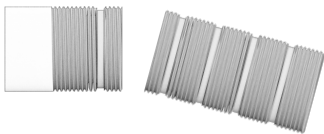

Nettoyer la coupe de toutes bavures tranchantes .

Deburr the cut from any sharp edges.



6

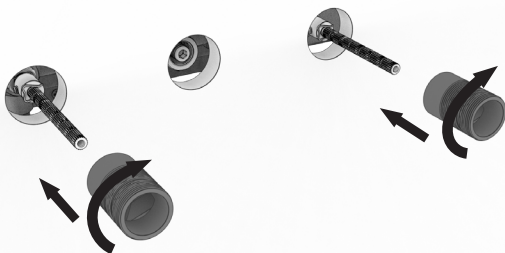

7

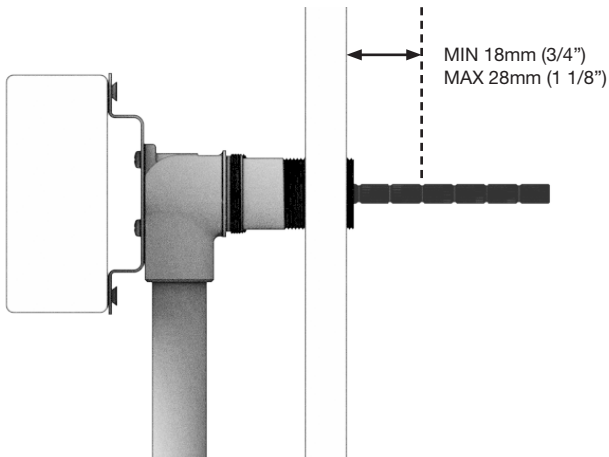

8



À l'aide d'une scie, couper à la ligne marquée à l'étape précédente.

With the help of a saw, cut along the marked line from previous step.



Protégez le mur.
Protect the wall.



9

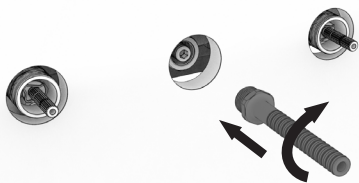

10

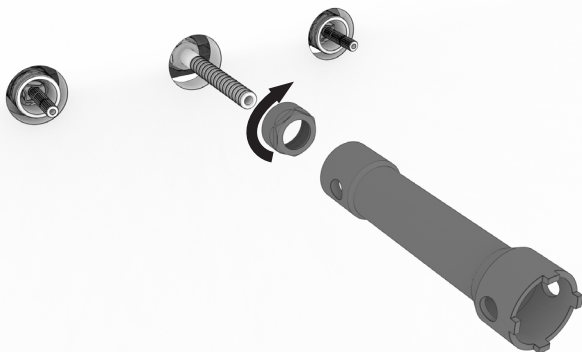

11

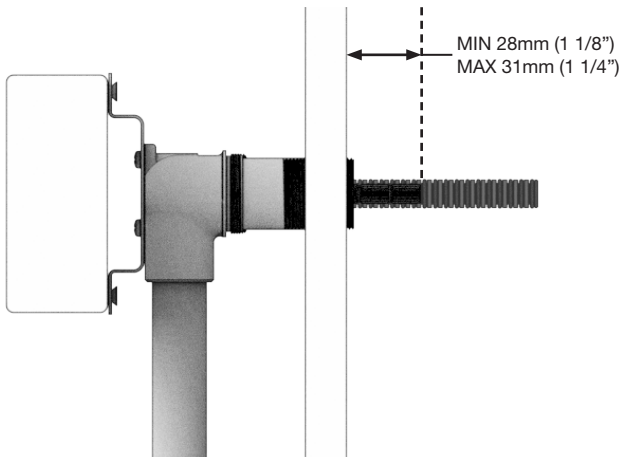

12

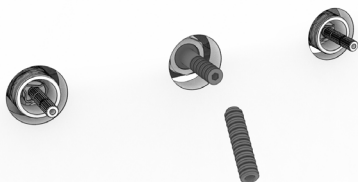

À l'aide d'une scie,
couper à la ligne
marquée à l'étape
précédente.

*With the help of a saw,
cut along the marked
line from previous
step.*



Protégez le mur.
Protect the wall.



13

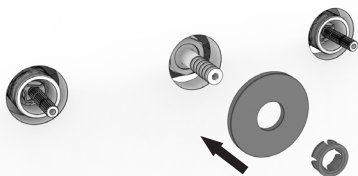

14a

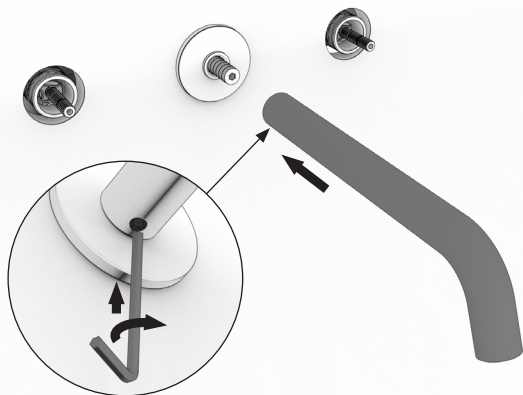

14b

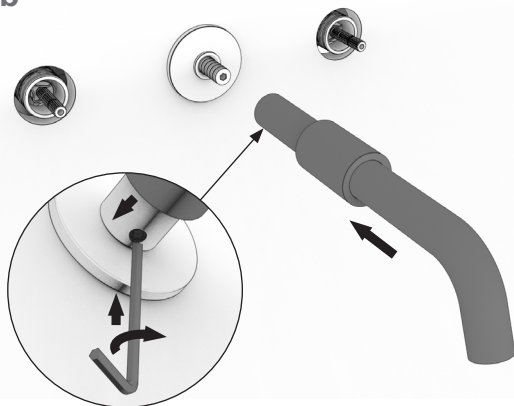

Ce plan d'installation peut servir pour plusieurs modèles.
This installation plan may apply to several models.

16



17



18

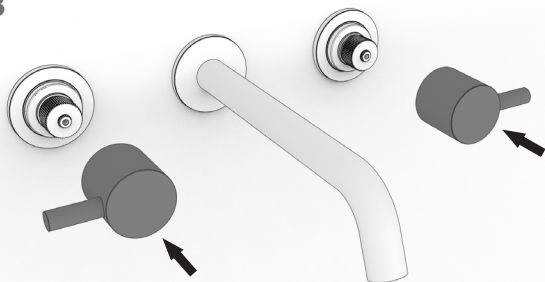

Les manettes doivent s'enclencher lorsqu'elles sont installées correctement.
The handles should snap on when installed properly.

19



Retirer l'aérateur et faire couler l'eau chaude et l'eau froide pendant 10 secondes afin de faire sortir tout débris qui aurait pu s'être glissé dans le robinet lors de l'installation. Remplacer ensuite l'aérateur en place.



Remove the aerator and run the hot and cold water for 10 seconds to flush out any debris that may have entered the faucet during installation. Replace the aerator when complete.

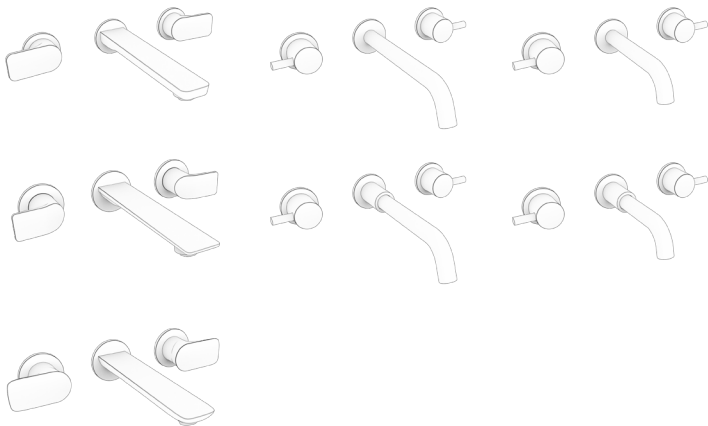

Ce plan d'installation peut servir pour plusieurs modèles.
This installation plan may apply to several models.

BARILDESIGN.COM