

3539LF-▲MPU

Submitted Model No.: _____

Specific Features: _____

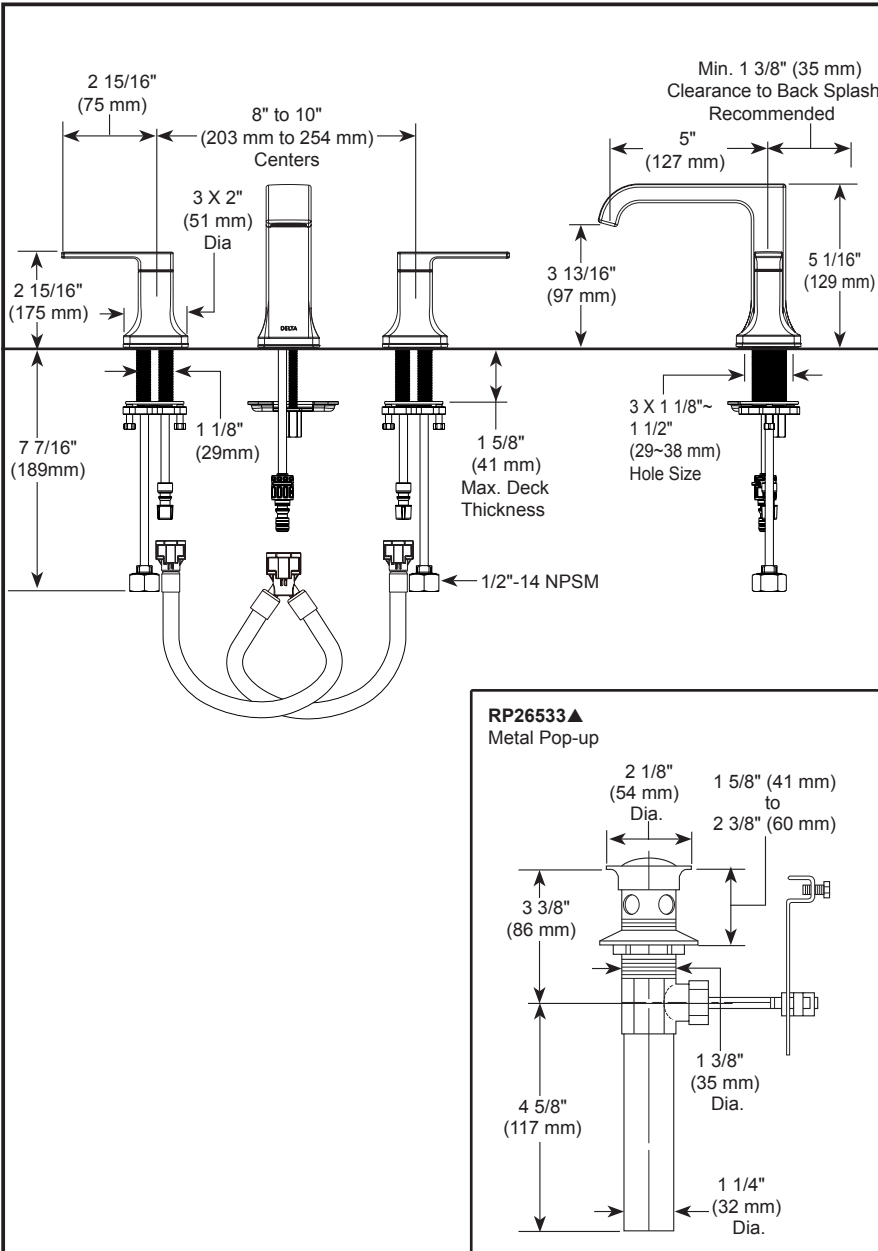

▲ Designate proper finish suffix

Delta reserves the right (1) to make changes in specifications and materials, and (2) to change or discontinue models, both without notice or obligation. Dimensions are for reference only. See current full-line price book or www.deltafaucet.com for finish options and product availability.

DSP-L-3539LF-MPU Rev. B



see what Delta can do™

BATHROOM FAUCET

- Velum™ Collection
- Two Handle Widespread Deck Mount

STANDARD SPECIFICATIONS:

- Max. flow rate 1.2 gpm @ 60 psi, 4.5 L/min @ 414 kPa
- Three hole mount
- Solid brass fabricated end valves
- Hot and cold stems are interchangeable
- 1/4 turn handle stops
- 1/2"-14 NPSM adapters
- Control mechanism is a rotating cylinder type with stainless steel plate and 90° rotation, with replaceable non-metallic seats
- Models include metal pop-up type fitting with plated flange and stopper
- Note: Standard mounting deck thickness can be extended by 1" (25mm) with RP10612

WARRANTY

- Parts and Finish - Lifetime limited warranty; or for commercial purchasers, 10 years for multi-family residential (apartments and condominiums) and 5 years for all other commercial uses, in each case from the date of purchase.
- Electronic Parts and Batteries (if applicable) - 5 years from the date of purchase; or for commercial purchasers, 1 year from the date of purchase. No warranty is provided on batteries.



COMPLIES WITH:

- ASME A112.18.1 / CSA B125.1
- ASME A112.18.2 / CSA B125.2
- ♿ Indicates compliance to ICC / ANSI A117.1
- EPA WaterSense®

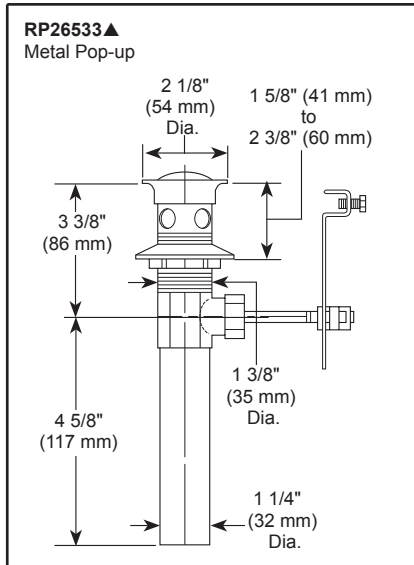

Delta Faucet Company
 55 E. 111th Street, Indianapolis, IN 46280
 350 South Edgeware Road, St. Thomas, ON N5P 4L1
 © 2023 Delta Faucet Company